

# AUTOVUE ELECTRO-MECHANICAL PROFESSIONAL

## KEY FEATURES AND BENEFITS

### KEY FEATURES

- View hundreds of 2D, 3D, EDA and Office document types
- Add digital markups and comments
- Create electro-mechanical virtual prototypes
- Take precise measurements
- Compare, section, and explode assemblies
- Perform 3D entity searches
- Access embedded PCB data
- Modify layer polarity for Gerber files
- Measure minimum distance between entities across layers
- Bill of Material (BOM) support with ability to select Board Side attributes
- Enhanced Display Modes
- Modify global transparency Cross-probe between a PCB layout, its related schematic, and 3D PCB
- Work Offline
- Hold real time collaboration sessions via the web
- Advanced printing capabilities

### KEY BENEFITS

- Extend the reach of engineering and product information to all enterprise users
- Bridge the gap between MCAD and EDA designs
- Enable cross functional team collaboration
- Standardize design reviews and shorten design cycles
- Reduce errors and accelerate time-to-market
- Validate PCB design integrity
- Drive innovation through improved communication
- Capture audit trail of decisions, changes and approvals
- Share documents securely without risking IP

*AutoVue Electro-Mechanical Professional is Oracle's all encompassing AutoVue solution, providing visibility into all engineering and product information. With AutoVue Electro-Mechanical Professional, organizations can bridge the gap between mechanical computer-aided design (MCAD) and electronic design automation (EDA), and extend the reach of product information and Computer Aided Design (CAD) data to all enterprise users. By enhancing cross-functional and departmental interaction earlier in the product development cycle, organizations can achieve improved productivity, reduced errors, and accelerated time to market.*

### Extend the Reach of Product Information to All Enterprise Users

AutoVue Electro-Mechanical Professional makes engineering, product and asset information, including 3D/2D CAD, EDA, Graphics, Office and PDF documents, available to all enterprise users, regardless of their technical skills and without requiring costly authoring applications. Team members are connected sooner in the product development process, and can make sound business decisions faster based on reliable information.

With AutoVue, users can also work with their product or asset information while offline. Offline workers or business travelers can take documents on site or on the road, work offline, and then update their comments or feedback once they are back on the network.

### Streamline Design Reviews and Capture Audit Trail

Global teams can review, verify and provide feedback on other disciplines' documents and designs using AutoVue Electro-Mechanical Professional digital markup capabilities. Cross-functional design review, change management and troubleshooting processes are vastly improved making it easier to identify errors or design flaws early in the process, minimizing costly rework and getting products to market faster. AutoVue digital markups also capture a reliable audit trail of all decisions, changes and approvals around product information.

### Drive Innovation through Improved Global Collaboration

AutoVue Electro-Mechanical Professional's built in real-time collaboration capabilities, help organizations to connect everyone in the global enterprise. Co-workers and partners alike can communicate as if they were in the same room and simultaneously review and mark up documents, exchange ideas, assign action items,

and resolve design issues in real time.

### Share Documents Securely without Risking Intellectual Property

AutoVue Electro-Mechanical Professional allows users to securely collaborate with extended teams and outsourced partners on sensitive documents without risking a company's valuable intellectual property (IP). AutoVue's unique streaming technology provides access to the full intelligence of documents without transferring the original files to the client desktop; originals never leave the server, and no local temp or cache files are created in the process, ensuring that a company's IP remains protected at all times.

### Support Green Initiatives

AutoVue Electro-Mechanical Professional can complement and support an organization's green initiatives. Instead of depending on printouts that they manually mark up, users can view, review, and annotate digital files. AutoVue can greatly reduce an organization's printing and paper costs, as well as shipping and handling expenses. AutoVue's real-time Web collaboration can replace face-to-face meetings, resulting in reduced travel costs, greater energy savings and productivity.

### Key Features and Capabilities

**View hundreds of document types.** AutoVue delivers native document viewing for hundreds of document types including 3D models, 2D drawings, PCBs layouts and schematics, Office and PDF files— without the authoring software and without undergoing costly and error-prone document conversions.

**Add markups and comments.** Add markups, as well as sound, video and graphic attachments to your documents. Easily manage and track feedback, change requests, and comments across multiple reviewers. Markups are saved as separate layers on top of the original document, which remains intact and is never altered.

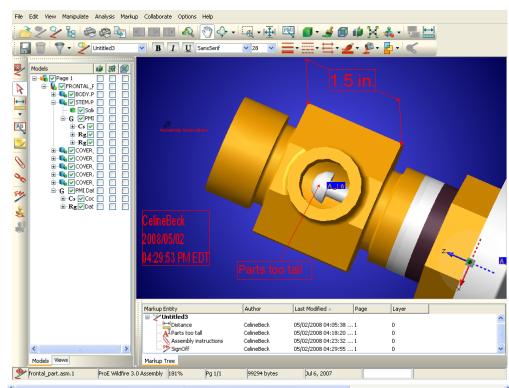

Figure 1: Add markups and comments on designs.

**Create Electro-Mechanical virtual prototypes.** Combine 3D parts (from different 3D CAD systems) and EDA designs into a single digital assembly to create virtual prototypes, check for interference, and validate design integrity.

**Enable digital sign-off** – Quickly approve markups and comments with digital sign-off. The sign-off stamp contains information about the markup author, date and time

of creation. Reviewers can also use AutoVue's IntelliStamp to electronically sign and stamp document sets with attributes from the back-office system. With IntelliStamp, users can trigger workflow actions directly from within documents reviewed in AutoVue, allowing for workflow automation and improved business processes.

### MCAD Features and Capabilities

**Precise measurements.** Speed up design reviews by performing precise measurements on 3D and 2D designs, including mass properties, distance, areas, angles, and more.

**Intelligent 3D Compare:** Instantly determine what has been added, removed, or unchanged in your designs by comparing 3D assemblies. This unique feature goes beyond a graphical comparison and includes the ability to detect changes to non-graphical attributes at the part or assembly level.

**Create exploded views.** Explode complex 3D assemblies to get to the component level faster and create clear illustrations for control documents, such as assembly and maintenance instructions.

**Section 3D Models.** Cross-section assemblies to draw attention to internal structures and assembly relationships or measure dimensions within individual parts.

**View 2D drafts.** Access the 2D drafts associated with 3D models.

**Perform 3D entity searches.** Quickly find the information you need by searching and filtering for parts in a 3D assembly based on a variety of native file attributes.

**Share product manufacturing information (PMI), geometric dimensioning and tolerance (GD&T), and functional tolerance annotation (FTA) data.** AutoVue delivers support for PMI, GD&T, and FTA data. Manufacturing personnel can instantly access, view, and review important product specifications and ensure that products are manufactured in compliance with design engineering's intent.

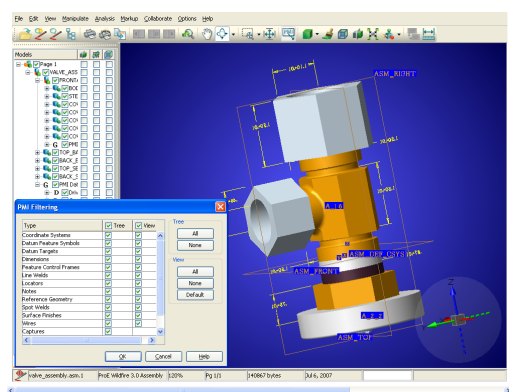

Figure 2: Share PMI, GD&T, and FTA data.

### EDA Features and Capabilities

**Access embedded intelligence in PCBs.** Access intelligence in a PCB by querying for attributes of traces, nets, components, and geometry library objects.

## INTEGRATE WITH ENTERPRISE APPLICATIONS

### ORACLE'S AUTOVUE ENTERPRISE VISUALIZATION SOLUTIONS

AutoVue solutions can be integrated into existing content management, product lifecycle management, or enterprise applications, such as ALM, & Project Planning to name a few. Integrated with existing enterprise systems, AutoVue connects information, people and processes, delivering anytime, anywhere access to vital information and maximizing business process efficiency.

Teams can better collaborate around their engineering and product documents and make sound business decisions, driving innovation and operational efficiency.

#### RELATED PRODUCTS

- AutoVue 2D Professional
- AutoVue 3D Professional Advanced
- AutoVue EDA Professional
- AutoVue Office
- AutoVue Mobile
- AutoVue VueLink Integrations

**Precise measurements.** Speed design reviews by precisely measuring to the end point or midpoint of a line, the intersection of two nets, the center of a circle, or any pin/via/symbol origin. Use the Minimum Distance tool to measure proximity of nets, pins, and pads to one another from the edge of the net or the components.

**Cross-probe between a PCB layout, its related schematic, or 3D PCB.** Facilitate design reviews and accelerate design verification with powerful cross-probing capabilities. Select a net or component in a schematic and it is instantaneously located and highlighted in the layout, or vice versa. Easily find all occurrences of a particular component or net and navigate between them, should they be present on multiple sheets of a schematic.

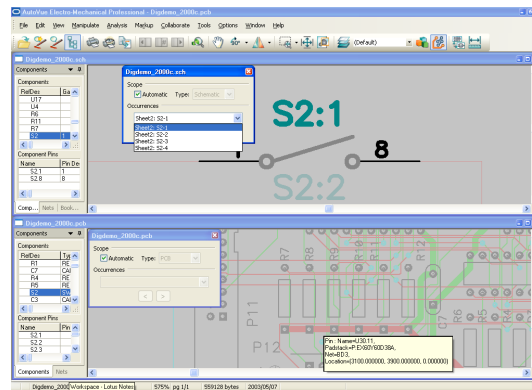

Figure 3: Cross-probe between PCB layouts, its related schematics, or 3D PCBs.

**Validate PCB design integrity.** Test for manufacturability or design violations by setting multiple tolerances or constraints. Then share this information with team members to shorten the design cycle and accelerate production.

**Compare EDA files:** Determine what has been added, removed, or unchanged in designs by comparing different versions of EDA files. Easily and accurately align and scale drawings while in EDA compare mode.

**Access entity properties.** Access important entity information without having to drill down into an entity's details. Entity properties are instantly displayed by hovering the mouse over a specific element of a schematic or PCB layout.

**Search for EDA elements.** Search for multiple components, nets, pins, vias, devices, or parts based on a variety of attributes, keywords, and values.

### Contact Us

For more information about how your organization can leverage the power of Oracle's AutoVue Electro-Mechanical Professional, please visit [oracle.com/applications/autovue](http://oracle.com/applications/autovue), call +1.800.363.5805 or +1.514.905.8400 to speak to an Oracle representative, or email [autovuesales\\_ww@oracle.com](mailto:autovuesales_ww@oracle.com).

Copyright © 2011, Oracle and/or its affiliates. All rights reserved. This document is provided for information purposes only, and the contents hereof are subject to change without notice. This document is not warranted to be error-free, nor is it subject to any other warranties or conditions, whether expressed orally or implied in law, including implied warranties and conditions of merchantability or fitness for a particular purpose. We specifically disclaim any liability with respect to this document, and no contractual obligations are formed either directly or indirectly by this document. This document may not be reproduced or transmitted in any form or by any means, electronic or mechanical, for any purpose, without our prior written permission. Oracle is a registered trademark of Oracle Corporation and/or its affiliates. Other names may be trademarks of their respective owners.